



EC Declaration of Conformity

KAC ALARM COMPANY LTD declares that the products identified below conform to the essential requirements that have been specified in the European Directive on Equipment and Protective Systems Intended for use in Explosive Atmospheres 94/9/EC. This Directive has been enacted into UK law by the Statutory Instrument No. 1996/192. The Equipment and Protective Systems Intended for use in Explosive Atmospheres Regulations 1996.

Product Type – Indoor surface / flush mounting intrinsically safe call point for use in fire detection and alarm systems.

Product Range – Intrinsically safe variants of the following product groups denoted by 'IS' as a postfix in the part number and marked in accordance with ATEX requirements.

MCP1A, MCP2A, MCP3A, MCP4A

This product range is manufactured by KAC Alarm Company Ltd at their premises; KAC House, Thornhill Road, North Moons Moat, Redditch, B98 9ND.

An EC Type Examination Certificate has been granted for this product range by the Notified Body Sira Test and Certification Ltd, Rake Lane, Eccleston, Chester, CH4 9JN. The identification number of this Notified Body is 0518

EC-Type Examination Certificate Number: SIRA 04ATEX2350X

This product range is Certified to the following standards:

EN50014:1997 + AMNDS 1 & 2
EN50020:2002
EN50284:1999

Compliant with the following standards:

EN60079-0:2011
EN60079-11:2011 Ed 6

These products meet the Essential Health & Safety Requirements of the above standards. Additional EHSRs have been identified and individually assessed in report R52A12288A.

This declaration is made for and behalf of KAC Alarm Company Ltd by the responsible person below who is authorised by KAC to make such a declaration.

Signature....  Ian Garden QHSE Manager
 Date of Issue 25 November 2011

KAC Alarm Company Limited
 KAC House, Thornhill Road, North Moons Moat,
 Redditch, Worcestershire B98 9ND



D970-2



Conventional I.S. Indoor Manual Call Point Installation Guide

General

Conventional I.S. Indoor Manual Call Point is available in two versions:

Part Number	Model Number	Product Name
55100-031	MCP1A-R470SF-A071-01IS	Conventional I.S. Indoor Manual Call Point-Red
55100-032	MCP1A-Y470SF-A071-01IS	Conventional I.S. Indoor Manual Call Point-Yellow

Conventional Indoor Manual Call Point

The Conventional I.S. Indoor Manual Call Point is supplied with a backbox for surface mounting. The call point is 'Type A' and is suitable for indoor use only. For flush mounting, a standard electrical outlet box with a minimum depth of 25mm is required.

Installation – General

The installation must conform to BS5839: Part 1 (or applicable local codes).

Installation

1. Fit the backbox (Fig 1) to the wall.
2. Run the cables into the backbox and connect them to the terminal block as shown in Fig 2. Ensure that functional earth/screen continuity is maintained.
3. Unlock the small front cover by inserting the forked key and pushing it home. Remove key, slide the cover down and remove the deformable element. Connect the terminal block as shown in Fig. 2, secure the call point to the backbox and refit the deformable element as required. Finally, replace the front cover in the reverse order in which it was removed and push it up until it locks.

The call points should be installed in a position where they will not be subjected to mechanical stresses and where the temperature is within operating temperature range. Areas where there are, or are likely to be, aggressive substances should be avoided.

Transparent Hinged Cover (flip lid)

To provide additional protection against accidental operation of call points, a transparent hinged cover, part no. 26729-152 is available.

To prevent against malicious activations of call points, locking tags are also available, part no. 26729-179 (pack of 5).

Please note that the call point does not conform to EN54-11 : 2001 when the hinged cover is secured with the locking tag.

Commissioning

Test each MCP using the test key provided. Ensure the control panel enters the alarm state.

Wiring Details

All wiring terminals accept solid or stranded cables up to 2.5mm².

Technical data

Maximum Voltage	30V
Maximum Switching Current	500mA
Alarm Resistor	470 Ω
IP rating	IP24D
Operating Temperature	-10°C to +55°C
Wattage	1W

Note: These ratings must not be exceeded

Troubleshooting

Before investigating individual units for faults, ensure the system wiring is fault free.

Routine testing

Insert the test key into the hole at the bottom of the call point and push home. Observe routine test requirements as specified in the applicable local codes. Apart from regular testing, as part of the scheduled maintenance of the fire alarm system, no additional maintenance is required.

Resetting

After testing, reset the call point by removing the test key and pushing up the front cover until it clicks home.

Important Information

The use of lubricants, cleaning solvents or petroleum based products should be avoided. Do not over tighten fixing screws.

Fault Finding

Problem	Possible Cause
Control panel reports zone fault	Incorrect zone wiring Detector removed
Control panel reports alarm	EOL device missing or incorrectly fitted MCP not reset Test key not removed
MCP does not activate alarm	Incorrect EOL device Incorrect wiring Incompatible control panel

For further information, please refer to PP2418.

These call points carry the following approvals:



II 1 G EEx ia IIC T4

Sira 04ATEX2350X



0518

They are designed and manufactured to protect against other hazards as defined in paragraph 1.2.7 of Annex II of the ATEX Directive 94/9/EC.

They are intended for indoor use within Intrinsically Safe (I.S.) Systems utilising suitable Safety Barriers.

Special conditions for safe use (denoted by X after the certificate number)

The enclosure is non-conducting and may generate an ignition-capable level of electrostatic charges under certain extreme conditions. The user should ensure that the equipment is not

installed in a location where it may be subjected to external conditions (such as high-pressure steam) which might cause a build-up of electrostatic charges on non-conducting surfaces. Additionally, cleaning of the equipment should be done only with a damp cloth. The equipment may be used in an ambient temperature range of -10°C to +55°C. These call points must not be modified in any way as doing so may invalidate the Certification and may compromise the safety of the product.

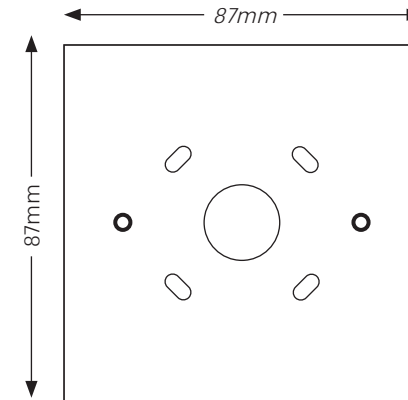

Fig 1 Backbox

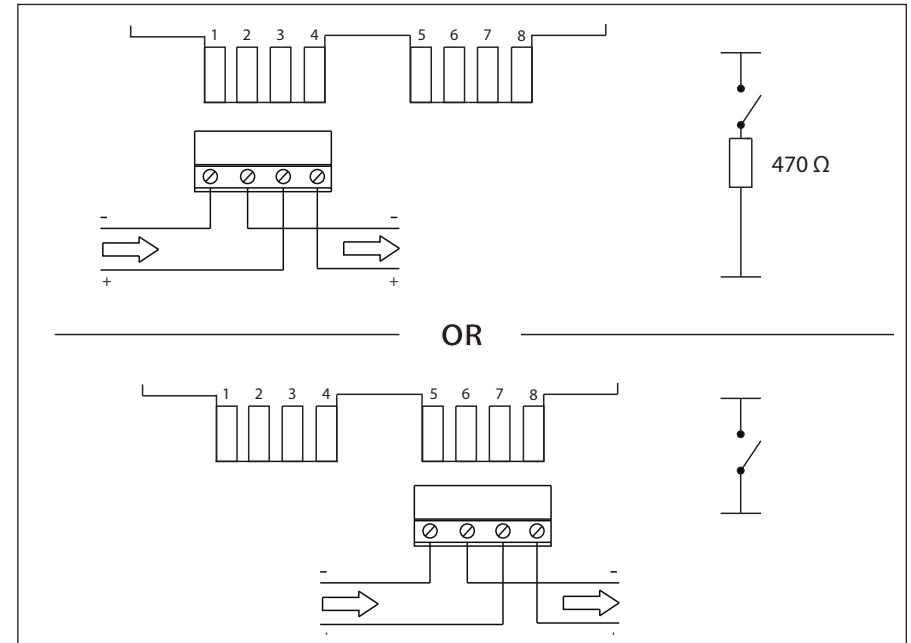

Fig 2 Terminal block connections